



# HURRICANE 500

## HURRICANE 500 SPECIFICATIONS

Manufactured by Industrial Vacuum Equipment Corporation.

- **TRAILER MOUNTED** Chassis - Tandem 7000# axles, 4" x 6" rectangular tube frame; four, 8 lug P235R- 16 ten ply, radials. DOT lighting with electric brakes.
- **POWER SOURCE** John Deere turbo-charged diesel engine, 6 cylinder, 170 HP @ 2400 RPM.
- **P.T.O (clutch)** Twin Disc 11.5"
- **VACUUM AIR FLOW (blower)** Positive displacement, 2350 CFM capable of 27" Hg, 5 belt driven with guard. (Roots 616 DVJ or equal)
- **FILTRATION SYSTEM (3-Stage)**  
 Stage 1: Cyclonic separation.  
 Stage 2: Baghouse / 37 Teflon coated, quick change filter bags with continuous reverse pulse air cleaning.  
 Stage 3: High efficiency blower safety filter.
- **HYDRAULICS** 3.5 GPM, 2200 PSI, direct driven
- **ENCLOSURE** Lockable steel shroud over engine. (fiberglass shroud available)
- **INSTRUMENT PANEL (fully enclosed)** 12 volt key start, Murphy safety system (low oil pressure/ high water temperature-auto shut down)  
 Gauges: oil pressure, water temperature, ammeter, tachometer with hour meter, filter cleaning on/off switch, material vacuum & dump time controls.
- **AIR COMPRESSOR** Direct drive Midland twin cylinder; water cooled and oil pressure fed. Midland air dryer with electronic heater.  
 AMSE certified air tank mounted on vibration isolators. (Provides air to pneumatic controls and the self cleaning filter system)

## STANDARD EQUIPMENT

- Paint-one color (custom lettering available)
- Wet or dry operation
- Tool box
- Automatic cone vibrator
- 100 gallon fuel tank
- Adjustable pintle hook
- Emergency stop button
- 10" inspection door (Hopper)

## OPTIONS

- Spare tire & carrier
- Cold weather package
- HEPA filtration
- Slide gate discharge
- Auxiliary 50 gallon fuel tank
- Hydraulic lift leg to level trailer
- 16" manhole on baghouse
- High reach package for discharge up to 11'
- Asbestos / hazardous waste package
- Parking brake
- Fiberglass locking shroud
- Auger in cone
- Auxiliary air hose 120 PSI
- Skid mount
- Hydraulic surge brake
- 4 point certified lifting cage
- 150 HP electric motor

## SAFETY FEATURES

- OSHA approved belt guard
- Remote emergency stop button
- Safety struts for baghouse
- Emergency brake away chain
- Wheel chocks
- Optional HEPA filtration
- Electric brakes
- Low oil or high temp engine shutdown



*Dimensional Drawing On Reverse Side*

**Pacific Industrial Equipment Corporation**  
 94-465 Koaki Street • Waipahu, HI 96797  
 866-402-2202 Toll Free

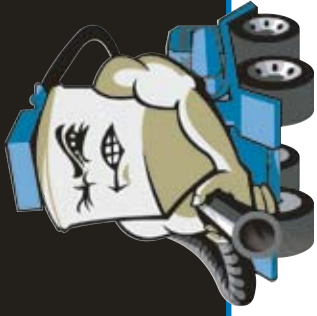

**HURRICANE™**

**HURRICANE  
500**

## DIMENSIONS

WIDTH 8'3"

WEIGHT 9,500 lbs.

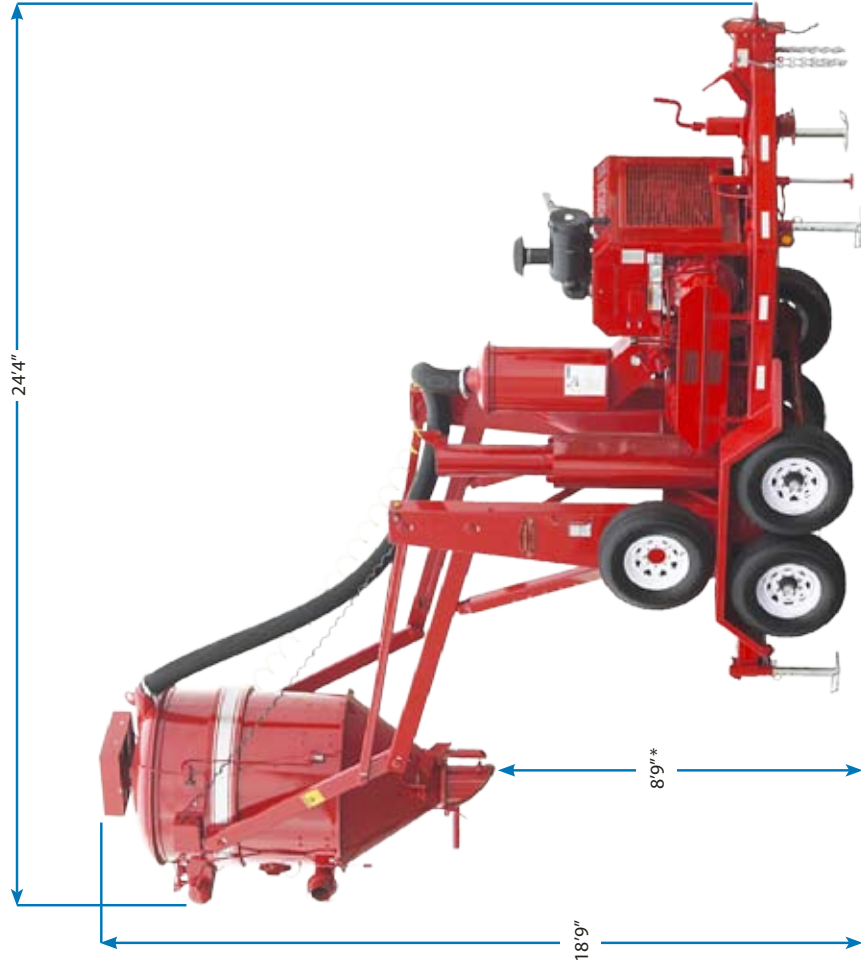

\* High reach options up to 11 ft available.